

Single Acting Hollow Cylinder

Series : LCH

Capacity : 10 - 100 Ton | Stroke Length : 41 - 155 mm | Working Pressure : 700 Bar



Cylinders are featured with centre hole through the entire cylinder body

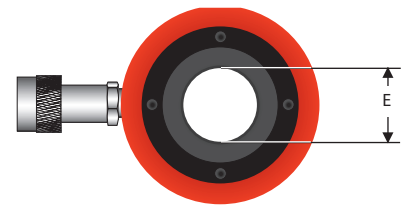

- High strength alloy steel construction.
- Hard chrome plating for cylinder bore, centre tube and piston rod to resist corrosion.
- Quick spring retraction.
- Can be operated in horizontal and vertical positions.
- Carry handle for heavy cylinders.
- Fitted with standard 3/8" NPT threaded female coupler.
- Supplied with removable saddles.
- Widely used for applications like wire rope pulling, prestressing, pully removing etc.

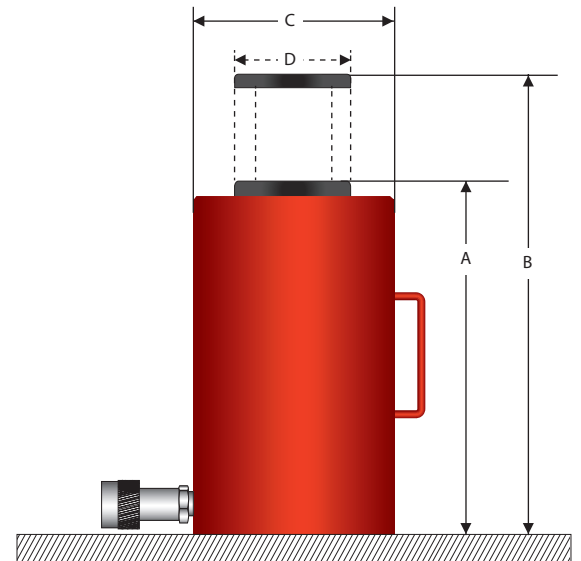

Model	Cylinder Capacity (Tons)	Stroke (mm)	Effective Area (cm ²)	Oil Capacity (cc)	Retracted Height (mm)	Extended Height (mm)	Cylinder Outer Dia (mm)	Piston Rod Dia (mm)	Center Hole Dia (mm)	Metric Tonnes @ 700 Bar	Weight (kg)
					A	B	C	D	E		
LCH1041	10	41	17.6	70.5	121	162	70	35	20	12.56	2.8
LCH2050	20	50	30.7	150	160	210	98	55	27	21.91	7.7
LCH2015		155	30.7	476	306	461	98	54.1	27	21.91	14.1
LCH3063	30	63	46.6	300.6	178	241	118	65	33	33.25	12
LCH3015		155	46.6	722	330	485	114	63.5	33	33.25	22
LCH6075	60	75	82.3	626	247	323	159	92	53.8	58.73	28
LCH6015		153	82.3	1259	332	485	159	92	53.8	58.73	35.4
LCH10075	100	75	133	1011	254	329	212	127	79	94.90	63