

# Short Cylinder

Series : LSC



Capacity : 10 - 200 Ton | Stroke Length : 25 mm - 100 mm | Working Pressure : 700 Bar



300 ton cylinder with 50mm stroke is available upon request



Ideal combination of closed height and stroke.

- Compact design.
- High strength alloy steel construction.
- Hard chrome plating for cylinder bore and piston rod to resist corrosion and provide longer life.
- Can be operated in horizontal and vertical positions.
- Fast spring retraction.
- Carry handle for heavy cylinders.
- Fitted with standard 3/8" NPT threaded female coupler.
- Wide range of applications in various industry sectors.

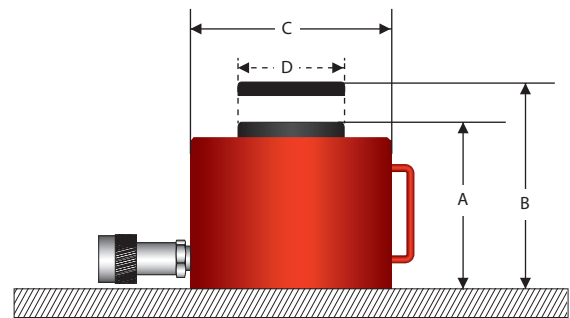

Model	Cylinder Capacity (Tons)	Stroke (mm)	Effective Area (cm <sup>2</sup> )	Oil Capacity (cc)	Retracted Height (mm)	Extended Height (mm)	Cylinder Outer Dia (mm)	Piston Rod Dia (mm)	Metric Tonnes @ 700 Bar	Weight (kg)
					A	B				
LSC1044	10	44	15.2	66	99	143	68	38	10.85	2.6
LSC2044	20	44	28.3	141.5	99	140	87	51	20.19	4.1
LSC2050		50	28.3	143	108	156			20.19	4.3
LSC3025	30	25	44.2	114	82	107	105	65	31.54	5
LSC3050		50	44.2	221	106	155			31.54	6.5
LSC5025	50	25	70.8	230	87	112	128	75	50.52	8
LSC5050		50	70.8	318	109	158			50.52	9.5
LSC10025	100	25	132.7	340	100	125	178	115	94.69	20
LSC10050		50	132.7	663	139	189			94.69	23
LSC100100		100	143	980	200	300			102.04	36
LSC15050	150	50	201	1005	170	205	215	140	143.43	37
LSC150100		100	201	2800	205	300			143.43	62
LSC20050	200	50	283.5	1417	193	243	245	150	202.29	63